

## FLASHLAMPS FOR PULSED LASERS AND FLASHLAMP POWER SUPPLIES

This lesson will introduce the student to the basic mechanical, optical, and electrical operation and concepts of flash lamps. Pulsed xenon and krypton flash lamps are used to convert electrical energy to optical radiation for pumping solid-state lasers and some dye lasers. Flash lamps are gas-discharge devices designed to produce pulsed radiation, unlike arc lamps, which are gas-discharge devices designed to produce continuous radiation.

The flash lamp is electrically pulsed to produce high values of radiation flux in a given spectral band. The type of flash lamp selected should be able to supply the maximum spectral output in the absorption bands of the laser material. Flash lamp specifications include lamp type and construction, arc length, bore diameter, gas-fill pressure, energy-handling capabilities, lifetime, and cooling requirements.

Figure 1 shows some typical lamp configurations. Linear flash lamps are in the form of straight tubes, with bore diameter of from 3 to 19 millimeters and a wall thickness of 1 to 2 millimeters. Lengths in the 5- to 10-centimeter region are common, but lamps as long as one meter are available.

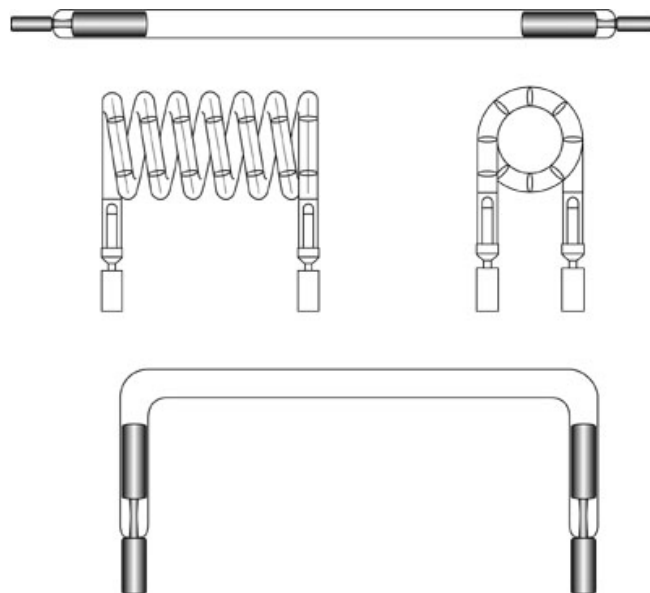

**Fig.1** Flash lamp types.

Top (a): Linear flash lamp.

Middle (b): Helical flash lamp, side and end views.

Bottom (c): U-shaped flash lamp

The lamp is filled to a pressure usually in the range of 300 to 700 torr. The fill gas is most often xenon.

### Electrical Characteristics of Flash lamps

All electrical discharges in gaseous media, including flashlamps and arc lamps, have common characteristics; The impedance characteristics of a flashlamp determine the energy-transfer efficiency from the capacitor bank to the lamp. The impedance is a function of time and current density. Flashlamp electrical characteristics can be discussed in three distinct areas of operation, which occur sequentially as the electrical discharge through the lamp develops.

The electrical characteristics of flashlamps are characterized by these three different operating regimes:

- Triggering and initial arc formation
- Unconfined discharge
- Wall-stabilized operation at high current.

The electrical resistance,  $R(t)$ , of a flashlamp as a function of time,  $t$ , is a function of the electrical current,  $I(t)$ , the lamp inside diameter,  $d$ , and the lamp length,  $L$ , between electrodes. The pulse shape for the current for a typical flashlamp pulse with duration of a few hundred microseconds is shown in Figure 2.

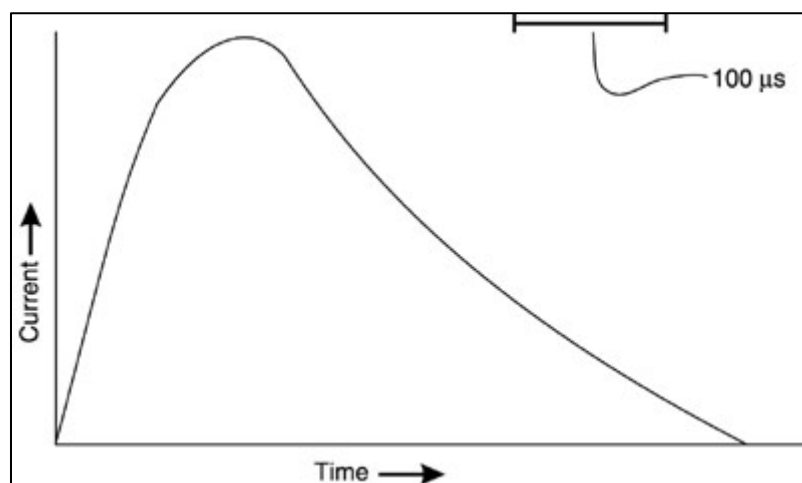

**Fig. 2** Typical waveform for a flashlamp current pulse lasting a few hundred microseconds

<b>Example B: Flashlamp Resistance</b>	
<b>Given:</b>	A xenon flashlamp with an inner diameter of 12 mm and an arc length of 6 inches (15.24 cm). The resistivity of xenon is assumed to be 0.020 $\Omega$ -cm.
<b>Find:</b>	Resistance of the lamp.
<b>Solution:</b>	$R = \frac{\rho \ell}{A}, A = \pi r^2$ $= \frac{(0.020 \Omega - \text{cm})(15.24 \text{ cm})}{(3.14)(0.6 \text{ cm})^2} =$ $\frac{0.3048 \Omega - \text{cm}^2}{1.131 \text{ cm}^2}$ $R = 0.27 \square$

### Power Supplies for Flashlamps

The power supply for a pulsed flashlamp performs a number of functions:

- Charges a capacitor that stores electrical charge until the flashlamp is ready to fire.
- Provides a trigger pulse that initiates the pulse.
- Controls the flow of current during the pulse to control the pulse shape.